

# GTS<sup>®</sup>, GTX and E-CLASS GAS TURBINE METERS



**AMERICAN**  
METER COMPANY

# An American Pioneer In Gas Measurement

Accuracy, repeatability, rangeability and flow range make gas turbine meters the preferred choice in an increasing number of gas measurement applications. American Meter's gas turbine meters, first introduced in 1968, now serve the gas industry in installations throughout the world.

Today's GTS/E-Class turbine meters incorporate refinements in design learned from years of application experience. Refinements that improve performance and reduce the cost of maintenance and ownership. American Meter gas turbines offer a mechanical output to drive a wide variety of auxiliary devices such as base volume correctors, plus electronic pulse outputs to interface with flow computers. Low, medium and high pressure models are available in 3-inch through 12-inch sizes.

## Models

Mechanical Drive Output

Mechanical and Electronic Pulse Outputs

Temperature Compensation

Standard and Extended Capacity Ranges with 45° or 30° Rotors

## Calibration Facilities

The American Meter gas turbine meter line is supported by three calibration facilities available for low, medium and high pressure testing and re-certifications.

- **Low Pressure**

Atmospheric pressure air testing is done on a high capacity sonic nozzle prover and on a 350-cubic foot (10-cubic meter) bell prover. Accuracy of the provers is traceable to the U.S. National Institute of Standards and Technology (formerly the National Bureau of Standards). Flow rates to 130,000 cubic feet per hour (370 cubic meters per hour).

- **Medium Pressure**

Medium pressure testing is conducted on a recirculating air loop at pressures to 150 psi (10 bar). The loop is available for certification or re-certification of meter performance under actual operating pressures. Certified master turbine meters are the reference standards.

- **High Pressure**

American Meter's high pressure test station, located at a gas storage field in northwestern Pennsylvania, is 30 minutes from the manufacturing plant. Test pressures to 750 psi (50 bar) and higher are available. Master turbine meters tested in Europe and at Southwest Research Institute are used as reference meters.



*Top and Middle Photos: High pressure test facilities.  
Bottom Photo: Low pressure 350 ft.<sup>3</sup> (10M<sup>3</sup>) Bell Prover.*

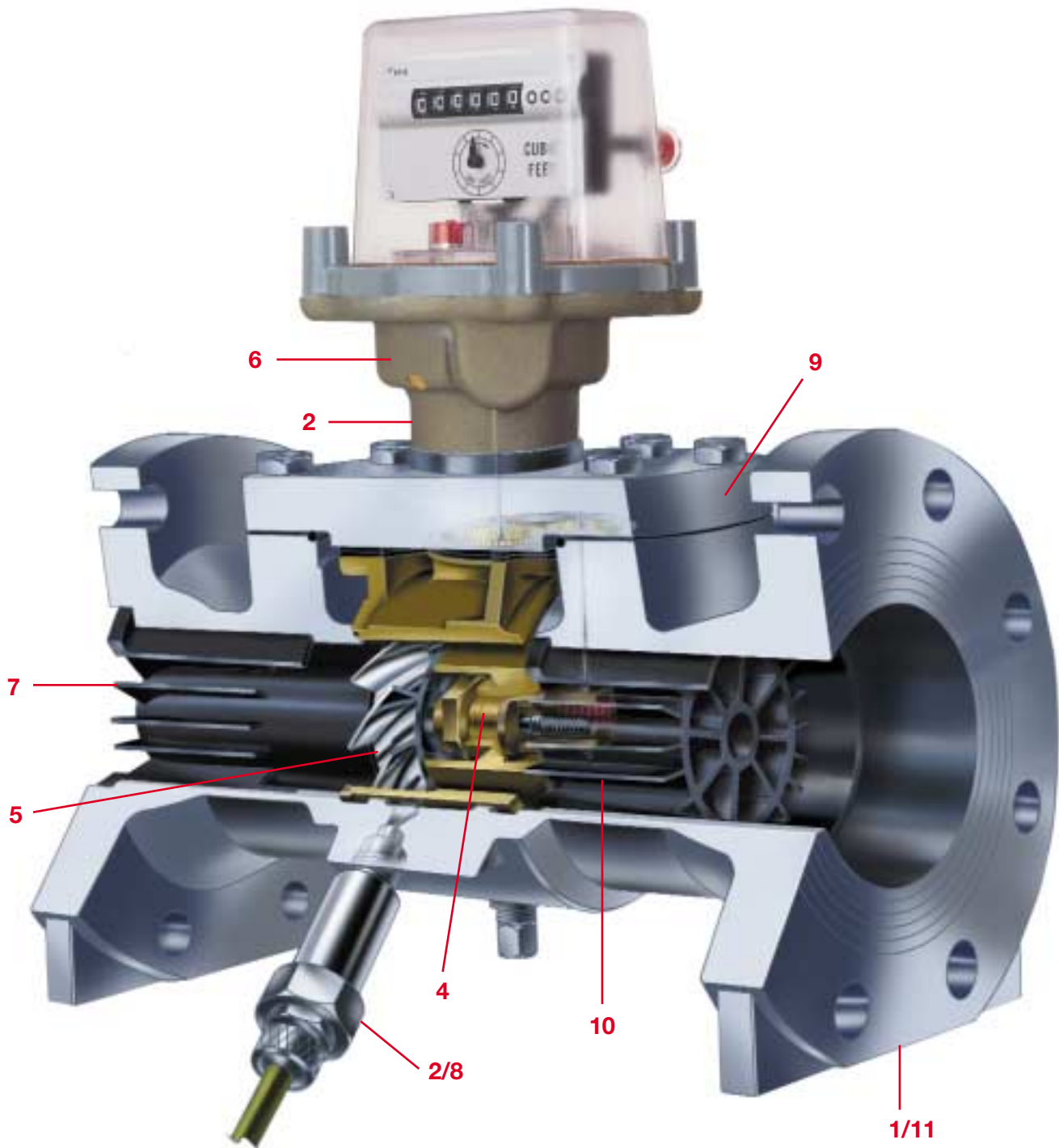

## Features And Benefits

- 1 Models with Extended Capacity Ratings** – can reduce the diameter of an entire meter run, resulting in substantial savings in piping, flanges, block valves, etc. See Capacity Tables.
- 2 Mechanical Drive Models** for use with P&T Correctors or **Electronic Pulse Output Models** to interface directly with popular flow computers.
- 3 Electronic Temperature Compensation** with Fixed Factor Pressure.
- 4 Flush-type Lubrication System** flushes main bearings while meter is in operation.
- 5 Aluminum Rotors** for high pressure models and for meters with high frequency pulse outputs.
- 6 One Output Gear Train** for all meter sizes; reduces spare parts inventory.
- 7 High Efficiency Inlet Flo-Guide®** flow conditioners to minimize the effects of flow disturbances in short coupled installations.
- 8 High Frequency Inductive Type Pulser** that monitors rotor condition.
- 9 Interchangeable Pre-calibrated Measurement Cartridges** for easy maintenance.
- 10 Pre-machined meter housings** to allow upgrade to AccuTest self-test model.
- 11 Additional housing** flange-to-flange dimensions available with new E-Class models.

### 3" GTS Capacities

Output Drive 100 Ft.<sup>3</sup> / 45° Rotor Angle

Line Pressure (psig)	1000 SCFH		Range Q <sub>max</sub> /Q <sub>min</sub>	Min. Actual Flow Rate MACFH	Press. Drop In. W.C.
	Q <sub>max</sub>	Q <sub>min</sub>			
0.25	10	0.83	12	0.83	4.5
5	13	0.96	14	0.73	6.0
10	17	1.08	15	0.65	7.5
15	20	1.18	17	0.59	9.0
20	23	1.28	18	0.55	10.5
25	27	1.37	20	0.51	12.1
50	44	1.76	25	0.40	19.7
75	61	2.08	30	0.34	27.3
100	79	2.36	33	0.30	35.0
125	97	2.62	37	0.28	42.6
150	114	3.35	40	0.30	50.2
175	132	3.07	43	0.24	57.9
200	150	3.28	46	0.23	65.5
275	205	3.86	53	0.20	88.4
300	224	4.04	55	0.19	96.1
400	301	4.72	64	0.17	127
500	379	5.35	71	0.15	157
600	461	5.95	78	0.14	188
700	545	6.52	84	0.13	218
800	632	7.09	89	0.13	249
900	722	7.64	95	0.12	279
1,000	814	8.18	100	0.12	310
1,100	910	8.71	104	0.12	340
1,200	1,007	9.24	109	0.11	371
1,300	1,106	9.76	113	0.11	402
1,400	1,197	10.18	118	0.11	432

Note: Capacity Table values established @ base pressure of 14.73 PSIA and base temperature of 60°F; 0.60 specific gravity gas. Supercompressibility included.

### 3" GTS Capacities

Output Drive 1.0m<sup>3</sup> / 45° Rotor Angle

Line Pressure		SCMH		Range Q <sub>max</sub> /Q <sub>min</sub>	Min. Actual Flow Rate Am <sup>3</sup> /h	Press. Drop mbar
Bar	kPa	Q <sub>max</sub>	Q <sub>min</sub>			
0.02	2	284	24	12	23.5	11.3
0.30	30	365	27	14	21.0	14.3
0.70	70	482	31	16	18.5	18.8
1.00	100	559	33	17	16.8	22.1
2.00	200	841	41	21	13.8	33.1
3.00	300	1,124	47	24	12.0	44.2
5.00	500	1,694	58	29	9.8	66.3
7.00	700	2,270	67	34	8.5	88.4
8.00	800	2,559	72	36	8.1	99.5
9.00	900	2,851	76	38	7.7	111
10.00	1,000	3,143	80	40	7.3	122
12.00	1,200	3,733	87	43	6.8	144
15.00	1,500	4,626	97	48	6.1	177
20.00	2,000	6,143	112	55	5.4	232
30.00	3,000	9,289	140	66	4.6	343
35.00	3,500	10,912	153	72	4.3	398
40.00	4,000	12,581	165	76	4.1	453
50.00	5,000	16,031	188	85	3.7	564
60.00	6,000	19,630	211	93	3.5	674
70.00	7,000	23,387	233	100	3.3	785
80.00	8,000	27,274	254	107	3.2	895
90.00	9,000	31,287	275	114	3.1	1,006
100.00	10,000	35,478	296	120	3.0	1,116

Note: Capacity Table values established @ base pressure of 101.325 kPa and base temperature of 15° C; 0.60 specific gravity gas. Supercompressibility included.



**4" GTS, GTX and E-Class Capacities – Output Drive 100 ft.<sup>3</sup>**

Line Pressure PSIG	45° Rotor Angle					30° Rotor Angle				
	Qmax MSCFH	Qmin MSCFH	Range Qmax/Qmin	Min. Actual Flow Rate MACFH	Press. Drop Inches W.C.	Qmax MSCFH	Qmin MSCFH	Range Qmax/Qmin	Min. Actual Flow Rate MACFH	Press. Drop Inches W.C.
0.25	18	1.2	15	1.20	2.4	23	1.9	12	1.92	3.9
5	24	1.4	17	1.06	3.2	30	2.2	14	1.65	5.2
10	30	1.5	19	0.90	4.0	38	2.5	15	1.48	6.5
15	36	1.7	21	0.85	4.8	46	2.7	17	1.36	7.8
20	42	1.8	23	0.77	5.6	54	3.0	18	1.26	9.1
25	48	2.0	25	0.75	6.4	62	3.2	20	1.18	10.5
50	80	2.5	31	0.58	10.5	102	4.1	25	0.93	17.1
75	110	3.0	37	0.50	14.6	142	4.8	30	0.79	23.7
100	142	3.4	42	0.43	18.7	182	5.4	33	0.70	30.3
125	173	3.8	46	0.40	22.7	222	6.0	37	0.64	36.9
150	206	4.8	50	0.43	26.8	263	7.7	40	0.69	43.5
175	239	4.4	54	0.34	30.9	304	7.1	43	0.55	50.2
200	271	6.0	57	0.41	34.9	346	7.6	46	0.52	56.8
275	370	5.5	66	0.28	47.2	472	8.9	53	0.45	76.6
300	403	5.8	69	0.27	51.2	516	9.3	55	0.44	83.3
400	540	6.8	80	0.24	67.5	691	10.9	64	0.39	110
500	695	7.7	89	0.22	83.8	872	12.3	71	0.35	136
600	830	8.6	97	0.21	100	1,060	13.7	78	0.33	163
700	981	9.4	104	0.19	116	1,254	15.0	84	0.31	189
800	1,138	10.2	112	0.18	133	1,455	16.3	89	0.29	216
900	1,299	11.0	118	0.18	149	1,661	17.6	95	0.28	242
1,000	1,466	11.8	124	0.17	165	1,873	18.8	100	0.27	269
1,100	1,637	12.5	130	0.17	182	2,092	20.0	104	0.26	295
1,200	1,812	13.3	136	0.16	198	2,315	21.2	109	0.26	322
1,300	1,991	14.0	142	0.16	214	2,544	22.4	113	0.25	348
1,400	2,154	14.7	147	0.15	230	2,754	23.4	118	0.24	375

Note: Capacity Table values established @ base pressure of 14.73 PSIA and base temperature of 60°F; 0.60 specific gravity gas. Supercompressibility included. Meters with 30° rotors have higher Qmax and Qmin values.

**4" GTS, GTX and E-Class Capacities – Output Drive 1.0m<sup>3</sup>**

Line Pressure		45° Rotor Angle					30° Rotor Angle				
		Qmax Sm <sup>3</sup> /h	Qmin Sm <sup>3</sup> /h	Range Qmax/Qmin	Min. Actual Flow Rate Am <sup>3</sup> /h	Pressure Drop mbar	Qmax Sm <sup>3</sup> /h	Qmin Sm <sup>3</sup> /h	Range Qmax/Qmin	Min. Actual Flow Rate Am <sup>3</sup> /h	Pressure Drop mbar
Bar	kPa										
0.02	2	509	34	15	34	6.0	651	54.1	12	53.9	9.8
0.30	30	657	39	17	30	7.7	841	61.9	14	48.3	12.6
0.70	70	867	45	19	27	10.1	1,109	71.4	16	42.6	16.4
1.00	100	1,006	48	21	24	11.8	1,287	76.4	17	38.7	19.3
2.00	200	1,513	59	26	20	17.8	1,935	93.7	21	31.7	29.0
3.00	300	2,022	68	30	17	23.7	2,587	108.5	24	27.5	38.7
5.00	500	3,047	83	36	14	35.5	3,897	133.5	29	22.5	58.0
7.00	700	4,082	97	42	12	47.4	5,221	154.9	34	19.6	77.4
8.00	800	4,603	103	45	12	53.3	5,887	164.6	36	18.5	87.0
9.00	900	5,127	109	47	11	59.2	6,558	174.0	38	17.6	96.7
10.00	1,000	5,654	114	49	11	65.1	7,231	182.9	40	16.9	106
12.00	1,200	6,714	125	54	10	77.0	8,587	199.8	43	15.6	126
15.00	1,500	8,320	140	60	9	94.7	10,641	223.2	48	14.1	155
20.00	2,000	11,049	162	68	8	124	14,132	258.7	55	12.5	203
30.00	3,000	16,707	201	83	7	184	21,368	321.9	66	10.5	300
35.00	3,500	19,626	220	89	6	213	25,101	350.9	72	9.9	348
40.00	4,000	22,628	237	95	6	243	28,941	379.1	76	9.4	397
50.00	5,000	28,834	271	106	5	302	36,878	433.2	85	8.6	493
60.00	6,000	35,306	303	116	5	361	45,155	485.0	93	8.1	590
70.00	7,000	42,064	335	126	5	420	53,799	535.6	100	7.6	687
80.00	8,000	49,054	366	134	5	480	62,740	584.8	107	7.3	783
90.00	9,000	56,272	396	142	4	539	71,970	632.9	114	7.0	880
100.00	10,000	63,810	426	150	4	598	81,612	681.2	120	6.8	977

Note: Capacity Table values established @ base pressure of 101.325 kPa and base temperature of 15° C; 0.60 specific gravity gas. Supercompressibility included. Meters with 30° rotors have higher Qmax and Qmin values.

**6" GTS, GTX and E-Class Capacities – Output Drive 100 ft.<sup>3</sup>**

Line Pressure PSIG	45° Rotor Angle					30° Rotor Angle				
	Qmax MSCFH	Qmin MSCFH	Range Qmax/Qmin	Min. Actual Flow Rate MACFH	Press. Drop Inches W.C.	Qmax MSCFH	Qmin MSCFH	Range Qmax/Qmin	Min. Actual Flow Rate MACFH	Press. Drop Inches W.C.
0.25	35	1.9	18	1.94	3.3	50	3.3	15	3.34	6.7
5	46	2.2	21	1.69	4.4	66	3.8	17	2.90	8.9
10	58	2.5	23	1.51	5.5	83	4.3	19	2.59	11.2
15	70	2.8	25	1.38	6.6	100	4.7	21	2.36	13.5
20	82	3.0	28	1.27	7.7	117	5.1	23	2.18	15.8
25	94	3.2	29	1.19	8.8	134	5.5	25	2.03	18.1
50	154	4.1	38	0.94	14.4	220	7.0	31	1.59	29.7
75	215	4.9	44	0.80	20.0	307	8.3	37	1.34	41.4
100	276	5.5	50	0.71	25.6	395	9.4	42	1.19	53.2
125	338	6.1	55	0.64	31.2	483	10.4	47	1.07	65.0
150	401	7.8	60	0.70	36.8	572	11.3	51	0.99	77.0
175	463	7.2	65	0.56	42.4	661	12.1	55	0.92	89
200	526	7.7	69	0.53	48.1	752	12.9	58	0.86	101
275	719	9.0	80	0.46	64.9	1,027	15.1	68	0.74	138
300	785	9.4	83	0.44	70.5	1,121	15.8	71	0.70	151
400	1,052	11.0	95	0.39	92.9	1,502	18.3	82	0.61	202
500	1,328	12.5	106	0.36	115	1,897	20.5	92	0.54	256
600	1,613	13.9	116	0.33	138	2,305	22.6	102	0.49	310
700	1,908	15.2	125	0.31	160	2,726	24.6	111	0.45	367
800	2,213	16.5	134	0.30	182	3,161	26.5	119	0.42	426
900	2,527	17.8	142	0.29	205	3,610	28.3	127	0.39	486
1,000	2,851	19.1	149	0.28	227	4,072	30.1	135	0.37	549
1,100	3,183	20.3	157	0.27	250	4,547	31.8	143	0.35	613
1,200	3,524	21.6	163	0.26	272	5,034	33.4	151	0.33	678
1,300	3,872	22.8	170	0.26	294	5,531	35.1	158	0.32	745
1,400	4,190	23.8	176	0.25	317	6,041	36.6	165	0.30	814

Note: Capacity Table values established @ base pressure of 14.73 PSIA and base temperature of 60°F; 0.60 specific gravity gas. Supercompressibility included. Meters with 30° rotors have higher Qmax and Qmin values.

**6" GTS, GTX and E-Class Capacities – Output Drive 1.0m<sup>3</sup>**

Line Pressure		45° Rotor Angle					30° Rotor Angle				
		Qmax Sm <sup>3</sup> /h	Qmin Sm <sup>3</sup> /h	Range Qmax/Qmin	Min. Actual Flow Rate Am <sup>3</sup> /h	Pressure Drop mbar	Qmax Sm <sup>3</sup> /h	Qmin Sm <sup>3</sup> /h	Range Qmax/Qmin	Min. Actual Flow Rate Am <sup>3</sup> /h	Pressure Drop mbar
Bar	kPa										
0.02	2	1,000	55	18	55	8.2	1,440	95.7	15	95.0	16.9
0.30	30	1,291	63	20	49	10.5	1,836	108.0	17	84.1	21.5
0.70	70	1,703	73	23	44	13.7	2,403	123.6	19	73.5	28.2
1.00	100	1,977	78	25	40	16.2	2,829	134.1	21	67.8	33.2
2.00	200	2,972	96	31	32	24.3	4,253	164.4	26	55.3	49.9
3.00	300	3,973	111	36	28	32.4	5,679	190.0	30	47.8	66.6
5.00	500	5,986	137	44	23	48.5	8,570	233.4	37	38.9	101
7.00	700	8,020	159	51	20	64.7	11,473	270.0	42	33.7	135
8.00	800	9,043	169	54	19	72.8	12,956	287.0	45	31.7	152
9.00	900	10,073	178	57	18	80.9	14,409	302.6	48	30.0	169
10.00	1,000	11,107	187	59	17	89.0	15,902	317.9	50	28.6	187
12.00	1,200	13,190	205	64	16	105	18,875	346.4	54	26.2	221
15.00	1,500	16,346	229	72	14	129	23,258	384.5	60	23.6	273
20.00	2,000	21,708	265	82	13	170	31,119	444.7	70	20.4	365
30.00	3,000	32,823	330	100	11	251	46,813	545.5	86	16.7	549
35.00	3,500	38,558	359	107	10	291	55,176	592.2	93	15.4	647
40.00	4,000	44,455	388	114	10	332	63,881	637.2	100	14.3	749
50.00	5,000	56,648	444	128	9	413	81,261	718.7	113	12.7	953
60.00	6,000	69,363	497	140	8	494	99,691	796.0	125	11.4	1,169
70.00	7,000	82,640	548	151	8	575	118,499	867.8	137	10.5	1,390
80.00	8,000	96,374	599	161	7	655	138,322	937.6	148	9.7	1,622
90.00	9,000	110,554	648	171	7	736	159,214	1,005.9	158	9.0	1,867
100.00	10,000	125,364	698	180	7	817	180,742	1,071.8	169	8.5	2,119

Note: Capacity Table values established @ base pressure of 101.325 kPa and base temperature of 15° C; 0.60 specific gravity gas. Supercompressibility included. Meters with 30° rotors have higher Qmax and Qmin values.

**8" GTS, GTX and E-Class Capacities – Output Drive 1,000 ft.<sup>3</sup>**

Line Pressure PSIG	45° Rotor Angle					30° Rotor Angle				
	Qmax MSCFH	Qmin MSCFH	Range Qmax/Qmin	Min. Actual Flow Rate MACFH	Press. Drop Inches W.C.	Qmax MSCFH	Qmin MSCFH	Range Qmax/Qmin	Min. Actual Flow Rate MACFH	Press. Drop Inches W.C.
0.25	60	3	20	3.00	1.6	88	5.9	15	5.87	3.4
5	79	3.5	23	2.61	2.1	116	6.8	17	5.11	4.5
10	100	3.9	26	2.33	2.7	146	7.6	19	4.56	5.7
15	120	4.3	28	2.13	3.2	177	8.3	21	4.16	6.8
20	141	4.6	31	1.97	3.7	207	9.0	23	3.85	8.0
25	161	4.9	33	1.84	4.3	237	9.6	25	3.60	9.1
50	265	6.3	42	1.45	7.0	388	12.4	31	2.83	14.9
75	369	7.5	49	1.23	9.7	541	14.6	37	2.41	20.7
100	474	8.5	56	1.09	12.4	695	16.6	42	2.14	26.4
125	580	9.4	62	0.99	15.2	850	18.4	46	1.95	32.2
150	686	12.1	67	1.08	17.9	1,006	23.6	50	2.11	38.0
175	794	11.1	72	0.86	20.6	1,164	21.6	54	1.68	43.7
200	902	11.8	76	0.81	23.3	1,324	23.1	57	1.59	49.5
275	1,232	13.9	89	0.71	31.4	1,807	27.2	66	1.38	66.8
300	1,345	14.6	92	0.68	34.2	1,973	28.5	69	1.33	72.6
400	1,803	17.0	106	0.60	45.0	2,645	33.2	80	1.18	95.7
500	2,276	19.3	118	0.55	55.9	3,339	37.7	89	1.08	119
600	2,766	21.4	129	0.51	66.7	4,056	41.9	97	1.00	142
700	3,271	23.5	139	0.48	77.6	4,798	45.9	104	0.95	165
800	3,794	25.5	149	0.46	88.5	5,564	49.9	112	0.90	188
900	4,332	27.5	158	0.44	99.3	6,354	53.8	118	0.87	211
1,000	4,887	29.4	166	0.43	110	7,167	57.6	124	0.84	234
1,100	5,457	31.4	174	0.41	121	8,004	61.3	130	0.81	257
1,200	6,041	33.3	182	0.40	132	8,860	65.1	136	0.79	280
1,300	6,638	35.1	189	0.39	143	9,735	68.7	142	0.77	303
1,400	7,184	36.7	196	0.38	154	10,536	71.7	147	0.75	326

Note: Capacity Table values established @ base pressure of 14.73 PSIA and base temperature of 60°F; 0.60 specific gravity gas. Supercompressibility included. Meters with 30° rotors have higher Qmax and Qmin values.

**8" GTS, GTX and E-Class Capacities – Output Drive 10m<sup>3</sup>**

Line Pressure		45° Rotor Angle					30° Rotor Angle				
		Qmax Sm <sup>3</sup> /h	Qmin Sm <sup>3</sup> /h	Range Qmax/Qmin	Min. Actual Flow Rate Am <sup>3</sup> /h	Pressure Drop mbar	Qmax Sm <sup>3</sup> /h	Qmin Sm <sup>3</sup> /h	Range Qmax/Qmin	Min. Actual Flow Rate Am <sup>3</sup> /h	Pressure Drop mbar
Bar	kPa										
0.02	2	1,700	85	20	84	4.0	2,500	166.3	15	165.5	8.7
0.30	30	2,195	97	23	76	5.1	3,228	190.1	17	148.4	11.1
0.70	70	2,895	112	26	67	6.7	4,257	219.2	19	130.8	14.6
1.00	100	3,360	120	28	61	7.9	4,942	234.6	21	119.0	17.2
2.00	200	5,053	147	34	50	11.8	7,431	288.0	26	97.3	25.7
3.00	300	6,755	170	40	43	15.8	9,933	333.4	30	84.5	34.3
5.00	500	10,176	209	49	35	23.7	14,965	410.0	36	69.3	51.5
7.00	700	13,635	243	56	31	31.6	20,051	475.8	42	60.3	68.7
8.00	800	15,373	258	60	29	35.5	22,607	505.8	45	57.0	77.3
9.00	900	17,125	273	63	28	39.5	25,184	534.5	47	54.2	85.8
10.00	1,000	18,882	287	66	26	43.4	27,768	561.9	49	51.8	94.4
12.00	1,200	22,423	313	72	24	51.3	32,974	613.8	54	47.8	112
15.00	1,500	27,788	350	79	22	63.2	40,865	685.6	60	43.4	137
20.00	2,000	36,903	405	91	20	82.9	54,269	794.8	68	38.4	180
30.00	3,000	55,799	504	111	16	122	82,057	989.0	83	32.3	266
35.00	3,500	65,548	550	119	15	142	96,394	1,078.2	89	30.3	309
40.00	4,000	75,574	594	127	15	162	111,139	1,164.8	95	28.8	352
50.00	5,000	96,301	679	142	13	201	141,619	1,330.8	106	26.4	438
60.00	6,000	117,917	760	155	13	241	173,407	1,490.0	116	24.8	524
70.00	7,000	140,488	839	167	12	280	206,600	1,645.4	126	23.5	610
80.00	8,000	163,836	916	179	11	320	240,936	1,796.5	134	22.5	695
90.00	9,000	187,941	992	190	11	359	276,384	1,944.3	142	21.6	781
100.00	10,000	213,119	1,067	200	11	399	313,410	2,092.8	150	21.0	867

Note: Capacity Table values established @ base pressure of 101.325 kPa and base temperature of 15° C; 0.60 specific gravity gas. Supercompressibility included. Meters with 30° rotors have higher Qmax and Qmin values.

**12" GTS Capacities**

**Output Drive 1,000 ft.<sup>3</sup> / 45° Rotor Angle**

Line Pressure (psig)	Q <sub>max</sub> MSCFH	Q <sub>min</sub> MSCFH	Range Q <sub>max</sub> /Q <sub>min</sub>	Min. Actual Flow Rate MACFH	Press. Drop In. W.C.
0.25	150	6.00	25	6.00	2.1
5	199	6.91	29	5.22	2.8
10	250	7.75	32	4.66	3.5
15	301	8.51	35	4.25	4.2
20	352	9.21	38	3.93	4.9
25	404	9.86	41	3.68	5.6
50	662	12.65	52	2.89	9.2
75	922	14.97	62	2.46	12.8
100	1,185	17.00	70	2.19	16.3
125	1,449	18.84	77	1.99	19.9
150	1,715	24.14	84	2.16	23.4
175	1,984	22.13	90	1.72	27.0
200	2,256	23.65	95	1.62	30.6
275	3,081	27.80	111	1.41	41.3
300	3,363	29.12	116	1.36	44.8
400	4,508	33.99	133	1.21	59.1
500	5,691	38.52	148	1.10	73.3
600	6,914	42.82	161	1.03	87.6
700	8,179	46.97	174	0.97	102
800	9,484	51.02	186	0.92	116
900	10,830	54.98	197	0.89	130
1,000	12,217	58.89	207	0.86	145
1,100	13,643	62.74	217	0.83	159
1,200	15,103	66.53	227	0.81	173
1,300	16,594	70.27	236	0.79	187
1,400	17,959	73.31	245	0.76	202

Note: Capacity Table values established @ base pressure of 14.73 PSIA and base temperature of 60°F; 0.60 specific gravity gas. Supercompressibility included.

**12" GTS Capacities**

**Output Drive 10m<sup>3</sup> / 45° Rotor Angle**

Line Pressure		Sm <sup>3</sup> /h		Range Q <sub>max</sub> /Q <sub>min</sub>	Min. Actual Flow Rate Am <sup>3</sup> /h	Press. Drop mbar
Bar	kPa	Q <sub>max</sub>	Q <sub>min</sub>			
0.02	2	4,289	171	25	170	5.2
0.30	30	5,512	195	28	152	6.7
0.70	70	7,269	225	32	134	8.7
1.00	100	8,438	240	35	122	10.3
2.00	200	12,689	295	43	100	15.4
3.00	300	16,962	342	50	87	20.5
5.00	500	25,554	420	61	71	30.8
7.00	700	34,239	487	70	62	41.0
8.00	800	38,604	518	74	58	46.2
9.00	900	43,004	548	79	55	51.3
10.00	1,000	47,416	576	82	53	56.4
12.00	1,200	56,307	629	90	49	66.7
15.00	1,500	69,782	702	99	44	82.1
20.00	2,000	92,670	814	114	39	108
30.00	3,000	140,121	1,013	138	33	159
35.00	3,500	164,603	1,105	149	31	185
40.00	4,000	189,780	1,193	159	29	210
50.00	5,000	241,829	1,363	177	27	262
60.00	6,000	296,110	1,527	194	25	313
70.00	7,000	352,790	1,686	209	24	364
80.00	8,000	411,422	1,841	224	23	416
90.00	9,000	471,954	1,992	237	22	467
100.00	10,000	535,179	2,144	250	22	518

Note: Capacity Table values established @ base pressure of 101.325 kPa and base temperature of 15° C; 0.60 specific gravity gas. Supercompressibility included.

### 3" GTS Basic Specifications

MAOP (psig)	Material (See Note C)	Horizontal (Figure 1) Dimensions (Inches)			Vertical (Figure 2) Dimensions (Inches)			Weight (lbs.)
		A	B	C	A	B	C	
275	AL	9	6.5	0.4	12.2	9.9	0.4	10
1,440	ST	11.1	6.5	0.4	14.5	9.9	0.4	20

Figure 1 - Horizontal Flow

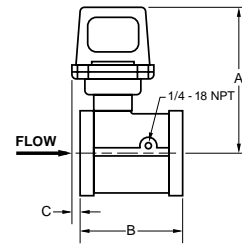

### 3" GTS (75 mm) Basic Specifications

MAOP		Material (See Note C)	Horizontal (Figure 1) Dimensions (mm)			Vertical (Figure 2) Dimensions (mm)			Weight (kg)
Bar	kPa		A	B	C	A	B	C	
19	190	AL	229	165	10	310	251	10	4.5
100	1,000	ST	282	165	10	368	251	10	9.0

Figure 2 - Vertical Flow

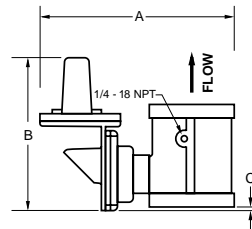

### 4" GTS, GTX and E-Class Basic Specifications (Figure 3)

MAOP psig	Material (See Note C)		Dimensions (Inches)				Flange				Approx. Shipping Weight (lb.)	Cart-ridge Bolt Torque (lb-ft.)	
							Inches		Bolts				
			Body	Top	A	B	B E-Class	C	O.D.	B.D.†			No.
175	AL	AL	5.85	14.0	15.50	-	9.00	7.50	8	5/8	150 FF	32	20
720	CS	AL	5.85	14.0	15.50	0.06	10.00	7.87	8	3/4	300 RF	150	68
1,440	CS	AL	5.85	14.0	15.50	0.25	10.75	8.50	8	7/8	600 RF	150	90

Figure 3 - 4" and 6" GTS

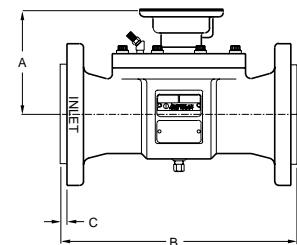

### 4" GTS, GTX and E-Class (100 mm) Basic Specifications (Figure 3)

MAOP		Material (See Note C)		Dimensions (Inches)				Flange				Approx. Shipping Weight (lb.)	Cart-ridge Bolt Torque (lb-ft.)	
Bar	kPa							Inches		Bolts				
Body	Top	A	B	B E-Class	C	O.D.	B.D.†	No.	Dia. (In.)	ANSI				
12	1,200	AL	AL	149	356	-	-	230	190	8	19	150 FF	14.5	27
50	5,000	CS	AL	149	356	394	1.5	255	200	8	22	300 RF	68	92
100	10,000	CS	AL	149	356	394	6.5	275	216	8	25	600 RF	68	122

### 6" GTS, GTX and E-Class Basic Specifications (Figure 3)

MAOP psig	Material (See Note C)		Dimensions (Inches)				Flange				Approx. Shipping Weight (lb.)	Cart-ridge Bolt Torque (lb-ft.)	
							Inches		Bolts				
	Body	Top	A	B	B E-Class	C	O.D.	B.D.†	No.	Dia. (In.)			ANSI
175	AL	AL	6.42	16.00	-	-	11.00	9.50	8	3/4	150 FF	54	35
720	CS	ST	6.92	18.00	22.50	0.06	12.50	10.62	12	3/4	300 RF	275	205
1,440	CS	ST	7.25	18.00	22.50	0.25	14.00	11.50	12	1	600 RF	275	300

**Operating Temperature Range:**

-40°F to +140°F  
-40°C to -60°C

### 6" GTS, GTX and E-Class (150 mm) Basic Specifications (Figure 3)

MAOP	Material (See Note C)		Dimensions (Inches)				Flange				Approx. Shipping Weight (lb.)	Cart-ridge Bolt Torque (lb-ft.)		
							Inches		Bolts					
	Bar	kPa	Body	Top	A	B	B E-Class	C	O.D.	B.D.†			No.	Dia. (In.)
12	1,200	AL	AL	163	410	-	-	279	241	8	22	150 FF	24.5	47
50	5,000	CS	ST	176	460	572	1.5	318	270	12	22	300 RF	125	278
100	10,000	CS	ST	188	460	572	6.5	356	292	12	29	300 RF	125	407

Manufacturing standards  
ANSI/ASME MFC - 4M - 1986  
AGA Report #7

**Note C:**

AL = Aluminum  
CS = Cast Steel  
ST = Steel

†B.D. = Bolt Circle Diameter

**8" GTS, GTX and E-Class Basic Specifications (Figure 3)**

MAOP psig		Material (See Note C)		Dimensions (Inches)				Flange				ANSI	Approx. Shipping Weight (lb.)	Cart-ridge Bolt Torque (lb-ft.)
								Inches		Bolts				
								O.D.	B.D.†	No.	Dia. (In.)			
175	AL	AL	7.42	21.00	-	-	13.50	11.75	8	3/4	150 FF	90	70	
720	CS	ST	7.92	23.00	27.25	0.06	15.00	13.00	12	7/8	300 RF	450	340	
1,440	CS	ST	8.42	23.00	27.25	0.25	16.50	13.75	12	1-1/8	600 RF	450	500	

**Figure 3 – 8" GTS**

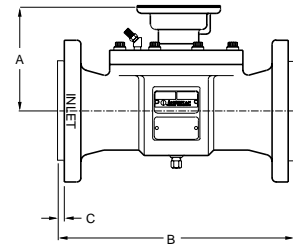

**8" GTS, GTX and E-Class (200 mm) Basic Specifications (Figure 3)**

MAOP Bar / kPa		Material (See Note C)		Dimensions (Inches)				Flange				ANSI	Approx. Shipping Weight (lb.)	Cart-ridge Bolt Torque (lb-ft.)
								Inches		Bolts				
								O.D.	B.D.†	No.	Dia. (In.)			
12	1,200	AL	AL	188	535	-	-	345	298	8	22	150 FF	47	95
50	5,000	CS	ST	201	585	693	1.5	385	330	12	25	300 RF	205	461
100	10,000	CS	ST	214	585	693	6.5	420	349	12	32	600 RF	205	678

**12" GTS Basic Specifications (Figure 4)**

MAOP psig		Material (See Note C)		Dimensions (Inches)			Flange				ANSI	Approx. Shipping Weight (lb.)	Cart-ridge Bolt Torque (lb-ft.)
							Inches		Bolts				
							O.D.	B.D.†	No.	Dia. (In.)			
175	ST	AL	15.35	29.00	0.06	19.00	17.00	12	7/8	150 FF	460	75	
275	ST	ST	15.35	29.00	0.06	19.00	17.00	12	7/8	150 RF	490	110	
720	ST	ST	15.85	30.25	0.06	20.50	17.75	16	1-1/8	300 RF	620	280	
1,440	ST	ST	16.35	32.75	0.25	22.00	19.50	20	1-1/4	600 RF	970	630	

**Figure 4 – 12" GTS**

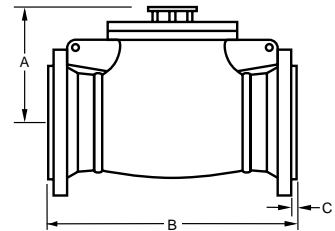

**12" GTS (300 mm) Basic Specifications (Figure 4)**

MAOP Bar / kPa		Material (See Note C)		Dimensions (mm)			Flange				ANSI	Approx. Shipping Weight (kg)	Cart-ridge Bolt Torque (Nm)
							Inches		Bolts				
							O.D. (mm)	B.D.† (mm)	No.	Hole Size (mm)			
12	1,200	ST	AL	390	740	1.5	483	432	12	25	150 FF	209	102
19	1,900	ST	ST	390	740	1.5	483	432	12	25	150 RF	222	149
50	5,000	ST	ST	403	770	1.5	521	451	16	32	300 RF	280	379
100	10,000	ST	ST	415	832	6.5	559	495	20	35	600 RF	440	854

## Ordering Information

<b>GTS</b>	<b>3"</b>	<b>4"</b>	<b>6"</b>	<b>8"</b>	<b>12"</b>
<b>MAOP</b>	275 psig/19 bar 1440 psig/100 bar	175 psig/12 bar 720 psig/50 bar 1440 psig/100 bar	175 psig/12 bar 720 psig/50 bar 1440 psig/100 bar	175 psig/12 bar 720 psig/50 bar 1440 psig/100 bar	175 psig/12 bar 275 psig/50 bar 1440 psig/100 bar
<b>ROTOR</b>	45° Plastic	45° Plastic 45° Metal 30° Metal	45° Plastic 45° Metal 30° Metal	45° Plastic 45° Metal 30° Metal	45° Plastic
<b>INDEX</b>	None Circle-Type Odometer-Type	None Circle-Type Odometer-Type	None Circle-Type Odometer-Type	None Circle-Type Odometer-Type	None Circle-Type Odometer-Type
<b>PULSER</b>	Low Frequency Medium Frequency	Low Frequency Medium Frequency High Frequency	Low Frequency Medium Frequency High Frequency	Low Frequency Medium Frequency High Frequency	Low Frequency Medium Frequency
<b>GTS E-CLASS</b>		<b>4"</b>	<b>6"</b>	<b>8"</b>	
<b>MAOP</b>		720 psig/50 bar 1440 psig/100 bar	720 psig/50 bar 1440 psig/100 bar	720 psig/50 bar 1440 psig/100 bar	
<b>ROTOR</b>		45° Plastic 45° Metal 30° Metal	45° Plastic 45° Metal 30° Metal	45° Plastic 45° Metal 30° Metal	
<b>INDEX</b>		None Circle-Type Odometer-Type	None Circle-Type Odometer-Type	None Circle-Type Odometer-Type	
<b>PULSER</b>		Low Frequency Medium Frequency High Frequency	Low Frequency Medium Frequency High Frequency	Low Frequency Medium Frequency High Frequency	
<b>GTX</b>		<b>4"</b>	<b>6"</b>	<b>8"</b>	
<b>MAOP</b>		175 psig/12 bar	175 psig/12 bar	175 psig/12 bar	
<b>ROTOR</b>		45° Plastic	45° Plastic	45° Plastic	
<b>INDEX</b>		None Circle-Type Odometer-Type	None Circle-Type Odometer-Type	None Circle-Type Odometer-Type	
<b>PULSER</b>		Low Frequency Medium Frequency	Low Frequency Medium Frequency	Low Frequency Medium Frequency	

## A Complete Family of Gas Measurement, Pressure Regulation, and Testing Systems



### Turbine Gas Meters

High-performance meters provide accurate measurement of high-volume gas flow. Turbines are available from 3" to 12" line sizes and line pressures up to 1440 psig. See bulletin SB 4510 for more information.



### Rotary Gas Meters

RPM Series Rotary Meters are designed for commercial and industrial loads to provide accurate flow measurement and outstanding performance in the most adverse conditions. See bulletin SB 5500 for more information.



### Diaphragm Meters

American Meter's compact, lightweight, aluminum case meters are designed to provide positive displacement accuracy for industrial or commercial loads. See bulletin SB 3510 for more information.



### Filters

Filtration down to 10 microns. Protects meter and regulator stations from dirt and pipe scale damage. See bulletin SB 12521 for more information.

**AMC Quality System** QMI is Accredited by:



ISO 9002 Certified



Dutch Council for Accreditation



*Measurement Engineers Since 1836*

Yesterday... Today... Tomorrow

300 Welsh Road, Building One  
Horsham, PA 19044-2234

Phone: 215/830-1800 • Fax 215/830-1890  
www.americanmeter.com



275 Industrial Road  
Cambridge, Ontario  
Canada N3H 4R7  
Phone: 519/650-1900 • Fax 519/650-1717  
www.americanmeter.com

*Represented by...*

**ELSTER**  **AMCO**

Printed in U.S.A. Core – PDF – 1/02