

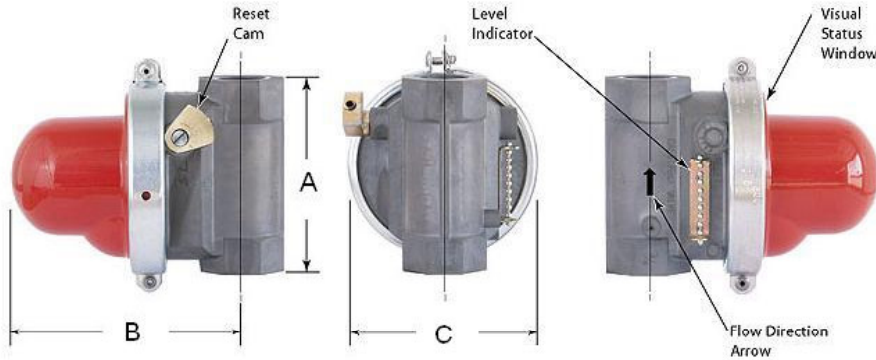

Koso/California Valve  
Pacific Seismic Products

# Seismic Shut-off Valve – 3/4" to 2" NPT

## Vertical – Bottom Entry



### Specifications & Response To Seismic Disturbance

- Manual Reset
- High flow efficiency with minimal pressure drop
- Positive closure, soft seal seating
- Visual open-close indicator
- Made in the USA
- Meets ASCE 25-97



Thread	Model No.	Max Pressure	Length A	Height B	Width C
3/4"	EV-VB300-7	7 PSI	4"	4 3/4"	3 7/8"
	EV-VB310-60	60 PSI			
1"	EV-VB301-7	7 PSI	4"	4 3/4"	3 7/8"
	EV-VB311-60	60 PSI			
1 1/4"	EV-VB302-7	7 PSI	5 1/4"	5"	3 7/8"
	EV-VB312-60	60 PSI			
1 1/2"	EV-VB303-7	7 PSI	5 1/4"	5"	3 7/8"
	EV-VB313-60	60 PSI			
2"	EV-VB314-60	60 PSI	5 5/8"	5"	3 7/8"

The valve shall close within five seconds when subjected to a horizontal, sinusoidal oscillation with the following characteristics:

Peak Acceleration	Period
1. 0.7G	0.13 Seconds
2. 0.4G	0.2 Seconds
3. 0.3G	0.4 Seconds
4. 0.25G	1.00 Seconds

The valve shall not close when subjected for five seconds to each of three horizontal, sinusoidal oscillations with the following characteristics:

Peak Acceleration	Period
1. 0.4G	0.1 Seconds
2. 0.2G	0.2 Seconds
3. 0.15G	0.40 Seconds
4. 0.10G	1.00 Seconds

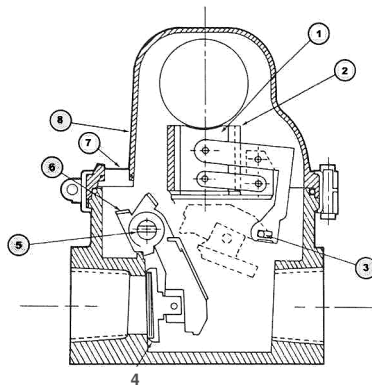

1. Stationary Post, supporting ball
2. Reacting cylinder
3. Rolling latch (no sliding friction)
4. Soft seat
5. Manual reset
6. Position indicator
7. Visual open-close indicator
8. Bonnet

### TYPICAL INSTALLATION

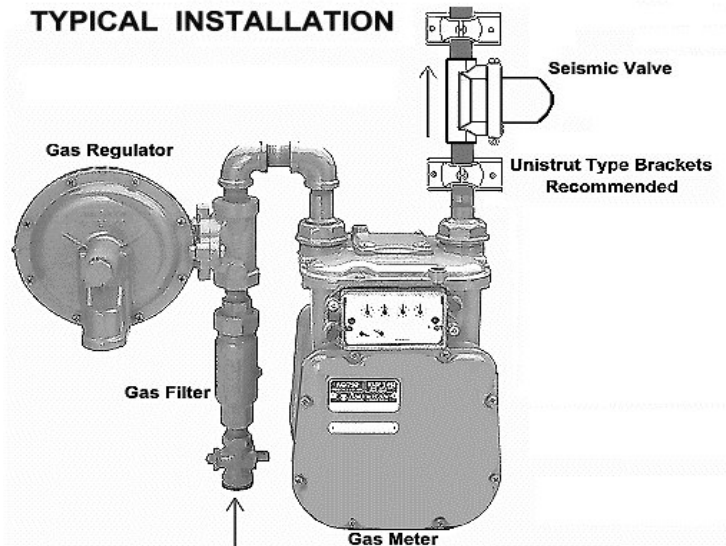

14629 200<sup>th</sup> Ave SE, Renton, WA 98059  
Tel: 888-64METER [888-646-3837] Fax: 888-646-3837  
sales@submetersystems.com, www.SubmeterSystems.com



# Seismic Shut-off Valve

## Capacity Charts

Capacity charts represent CFH of natural gas at 60° F

Use the following charts to determine the approximate loss of pressure (in inches water column) through the valve.

1. Identify maximum inlet pressure to the valve.
2. Identify maximum Cubic Feet/Hour - CFH
3. See Column 1 for the pressure drop.

### 3/4" EV-VB300-7 EV-VB310-60

CV=21 (Equivalent Length of Pipe = 3')

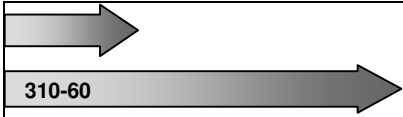

"W.C. Drop	Inlet Pressures - CFH					
	8"	14"	3 PSI	10 PSI	15 PSI	20 PSI
0.1	362	365	394	465	510	551
0.2	512	516	556	657	721	779
0.3	627	631	681	805	883	954
0.4	724	729	787	930	1019	1102
0.5	809	815	880	1039	1140	1232
0.6	886	893	963	1138	1248	1349
0.7	957	964	1040	1229	1346	1457
0.8	1023	1031	1112	1314	1441	1558
0.9	1085	1093	1180	1374	1529	1652
1	1144	1152	1243	1469	1611	1742
2	1616	1627	1756	2076	2277	2462
3	1976	1990	2149	2510	2787	3013
4	2279	2296	2479	2932	3216	3478
5	2545	2564	2769	3275	3594	3886

### 1" EV-VB301-7 EV-VB311-60

CV=41 (Equivalent Length of Pipe = 3')

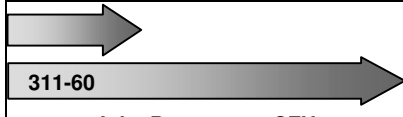

"W.C. Drop	Inlet Pressures - CFH					
	8"	14"	3 PSI	10 PSI	15 PSI	20 PSI
0.1	707	712	768	908	995	1076
0.2	1000	1007	1086	1283	1407	1521
0.3	1224	1233	1330	1572	1724	1863
0.4	1413	1423	1536	1815	1990	2151
0.5	1580	1591	1717	2029	2225	2405
0.6	1731	1743	1881	2222	2437	2634
0.7	1869	1882	2031	240	2632	2845
0.8	1998	2012	2171	2566	2814	3042
0.9	2119	2134	2303	2721	2984	3226
1	2233	2249	2427	2868	3145	3400
2	3154	3177	3429	4053	4446	4806
3	3858	3886	4196	4961	5442	5883
4	4450	4482	4840	5724	6280	6790
5	4969	5005	5406	6395	7017	7588

### 1 1/4" EV-VB302-7 EV-VB312-60

CV=64 (Equivalent Length of Pipe = 4')



"W.C. Drop	Inlet Pressures - CFH					
	8"	14"	3 PSI	10 PSI	15 PSI	20 PSI
0.1	1103	1111	1199	1417	1554	1679
0.2	1560	1571	1696	2003	2197	2375
0.3	1911	1924	2077	2453	2690	2908
0.5	2466	2484	2681	3167	3473	3764
0.6	2701	2721	2936	3469	3804	4112
0.7	2917	2938	3171	3747	4109	4441
0.8	3118	3141	3390	4005	4392	4748
0.9	3307	3331	3595	4248	4658	5036
1	3486	3511	3789	4477	4910	5308
2	4924	4959	5353	6327	6940	7502
3	6023	6066	6549	7743	8494	9184
4	6946	696	7555	8935	9802	10599
5	7757	7813	8438	9982	10953	11844

### 1 1/2" EV-VB303-7 EV-VB313-60

CV=101 (Equivalent Length of Pipe = 5')

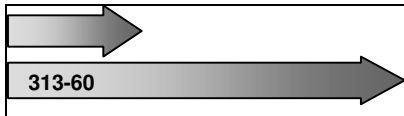

"W.C. Drop	Inlet Pressures - CFH					
	8"	14"	3 PSI	10 PSI	15 PSI	20 PSI
0.1	1741	1754	1893	2236	2452	2650
0.2	2462	2480	2676	3162	3467	3748
0.3	3015	3037	3277	3872	4246	4590
0.5	3892	3920	4230	4888	5481	5924
0.6	4263	4293	4633	5474	6004	6490
0.7	4604	4637	5004	5913	6484	7009
0.8	4921	4956	5349	6320	6931	7493
0.9	5219	5256	5673	6703	7351	7947
1	5501	5540	5979	7065	7749	8376
2	7770	7826	8448	9985	10952	11840
3	9505	9573	10336	12220	13405	14493
4	10962	11041	11922	14100	15469	16727
5	12241	12330	13316	15753	17285	18691

### 2" EV-VB314-60

CV=164 (Equivalent Length of Pipe = 5')

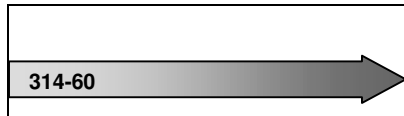

"W.C. Drop	Inlet Pressures - CFH					
	8"	14"	3 PSI	10 PSI	15 PSI	20 PSI
0.1	2828	2848	3073	3630	3981	4303
0.2	3998	4027	4346	5134	5630	6085
0.3	4896	4931	5322	6287	6894	7452
0.5	6320	6365	6869	8115	8899	9620
0.6	6922	6971	7524	8889	9748	10537
0.7	7476	7529	8126	9601	1052	11381
0.8	7991	8048	8686	10263	11255	12166
0.9	8475	8535	9212	10885	11937	12904
1	8932	8996	9709	11473	12582	13601
2	12617	12707	13717	16213	17783	19225
3	15434	15545	16783	19842	21766	23533
4	17800	17928	19359	22895	25118	27160
5	19877	20020	21622	25579	28066	30350