

AMC Quality System
QMI is Accredited by:



ISO 9001 Certified
Certificate #006697



Dutch Council
for Accreditation



special application • residential gas meter

5 PSI MAOP and 250 cfh (.60 gravity gas) at 1/2-inch w.c. differential

AM-250

AM-250

- One-piece, die-cast aluminum case, side connected
- Oil impregnated, self-lubricated bearings
- Convolute duramic diaphragms
- Rigid, reinforced flag rods
- Graphite-filled phenolic valves
- Long-life grommet seals
- Odometer index standard
- Hanging brackets available
- Automatic meter reader compatibility
- Temperature compensation available from -30°F to 140°F
- 15-year warranty
- 10 LT female connection only

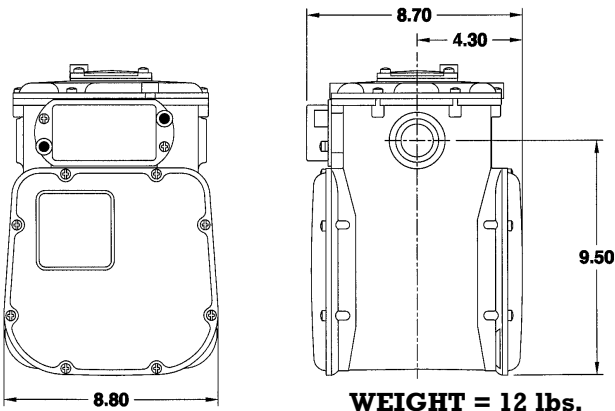

Reference Materials

Installation Instructions	AIM-3715
Operation/Maintenance	
Manual & Video	52722P002
Repair Parts List	RPL-3835

APPLICATIONS —

The ideal meter for measuring gas to mobile home parks, for LPG applications, or wherever US standard pipe thread connections are desirable. Properly installed, this meter will accurately measure gas loads ranging from one pilot light to its full recommended capacity.

Rated Gas Capacity For 0.60 S.G. Gas

Inlet Pressure PSIG	Inches W.C. Differential	Capacity SCFH
.25	1/2"	250 ^{1,2}
.25	2"	514
1	2"	528
2	2"	550
5	2"	593
10	2"	671

1 - Propane - 158 cfh
2 - Butane - 138 cfh

AM-250 CAPACITY CURVE @ .25 PSIG inlet

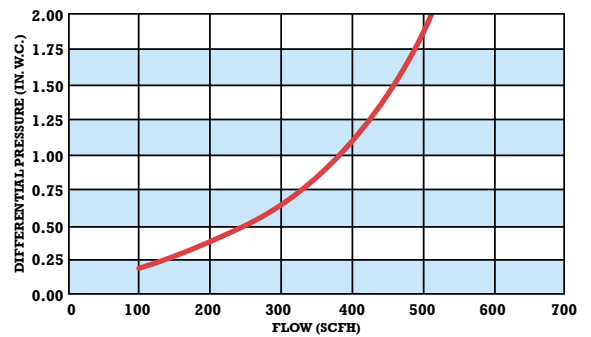

AM-250 PROOF CURVE

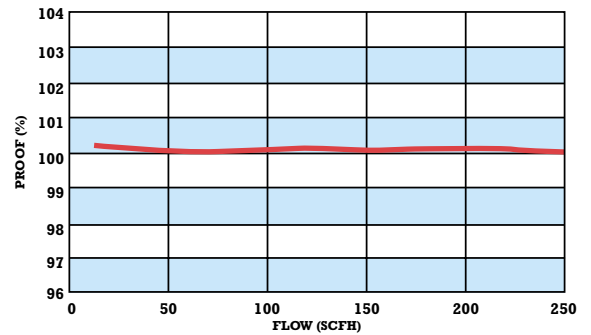

Order Information:

Model No.: _____

Regular or Temperature Compensated: _____

U.S. or Metric: _____

Type of Index: _____

Proof Preference: 100 +/- 1% _____

Standard Color or ASA #49 Grey: _____

Contact American Meter with any questions or orders at the address and phone number below.



American Meter

300 Welsh Road, Building One • Horsham, PA 19044-2234 • USA
Tel: (215) 830-1800 • Fax: (215) 830-1890



Canadian Meter

3037 Derry Road, West • Milton, Ontario L9T 2X6 • Canada
Tel: (905) 878-2361 • Fax: (905) 878-5758